

eShelf[®]

ESP50

35" Digital Stretch Screen

Sale

Engaging shelf signage.



The 35" Digital Stretch Screen is a sleek, high-definition display designed for 24/7 operation, making it perfect for continuous use in retail, hospitality, and other commercial settings. This stand-alone unit supports independent playback, allowing you to effortlessly display content without needing a network connection. Ideal for digital signage applications that require clear, eye-catching visuals in compact spaces.

Whether you're showcasing promotions, menus, or product information, this durable and energy-efficient display delivers sharp, vibrant content around the clock.

Vibrant

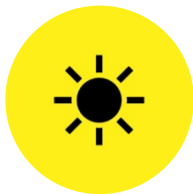

Our high-definition LCD display delivers crystal-clear visuals with vibrant colors and sharp details, ensuring your content stands out with stunning clarity.

Convenient



This stand-alone unit offers hassle-free operation, allowing you to play content directly without the need for a network or external connections.

Reliable



Supports 24/7 continuous operation, ensuring your content stays visible and engaging around the clock.

Let your message stand out

With a vibrant digital display.

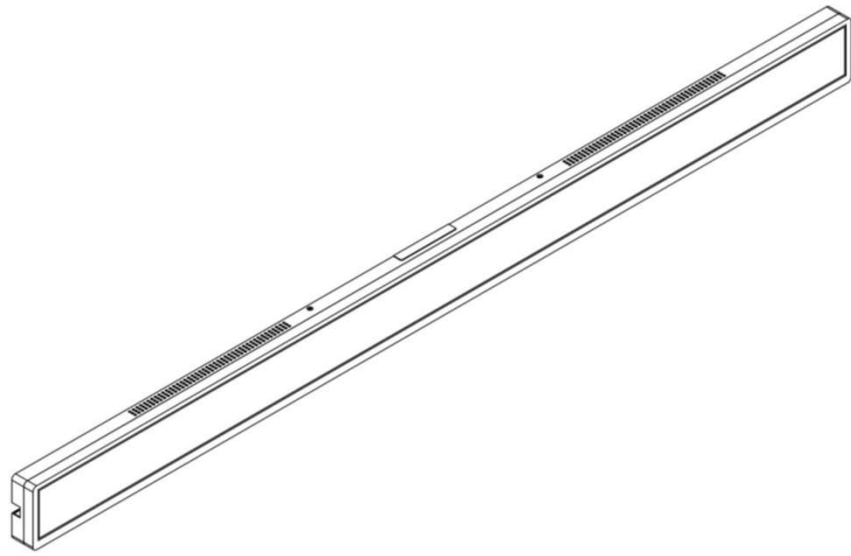

Panel

Size	35"
Active area	878.4(H) x 48.19(V) mm
Resolution	3840(V) x 200(H)
Backlight	LED
Lifespan	50000 hours
Viewing angle	178°(V) x 178°(H)
Contrast	1000: 1
Frequency	60 Hz
Display color	1.07B
Response time	8 ms

Systems

CPU	T972 Quad core ARM Cortex-A55 1.9GHz
RAM	2G (4G/8G optional)
ROM	16G EMMC (32G/64G EMMC optional)
Memory extension	128G TF, TF Card extension with the highest support for 128GB
Networks	Built-in WIFI (default 2.4G single frequency, configurable to 2.4G/5G dual frequency)
Bluetooth	Bluetooth V4.2
Interface	1*micro USB (OTG), 1*USB-A, 1*TF card, 1*USB-C Power Input (DC12V). Must match with our special adapter for power supply
OS	Android 9.0

Mechanical Packaging

Dimension	891.6 x 60.4 x 23.0mm
N.W	≤ 1.5KG
Packing Dimension (5 Pcs/CTN)	1120 x 320 x 140mm
G.W.	7.55KG

Accessories

Optional	Power adapter, Mounting bracket, OTC cable
----------	--

Power

Power consumption	≤18W
Voltage	DC 12V

Environment

Working environment	Temperature: 0°C ~ 50°C Humidity: 10% ~ 85% Atmospheric Pressure: 86kPa ~ 104kPa
Storage environment	Temperature: -20°C ~ 60°C Humidity: 5% ~ 95% Atmospheric Pressure: 86kPa ~ 104kPa

Warranty

Year	2Y
------	----

Supported Media Formats

- Audio - MP3, WMA, WAV, APE, FLAC, AAC, OGG, M4A, 3GPP formats
- Video - Multi-format 1080P 60fps video decoding (H.265, H.264, VC-1, MPEG-1/2/4, VP8), 1080P video encoding, supports H.264, VP8
- Picture - Supports browsing of various image formats such as JPG, BMP, PNG and supports rotation/slideshow/image enlargement functions

Note: LCD screens, including eShelf, may experience image retention or burn-in without effective content management.

What is Image Retention?

Image retention refers to any image that "sticks" on a screen, even when the content changes. It usually appears as a faint ghost that fades after a moment.

What is Image Burn-In?

Burn-in is a form of image retention that lasts much longer. It is a visible mark that remains, no matter what you are watching or doing.

Causes of Burn-In

- Videos that have a static logo, such as product logos, can leave a burn-in if displayed for a prolonged period
- Pausing a video and leaving the eShelf on for prolonged periods



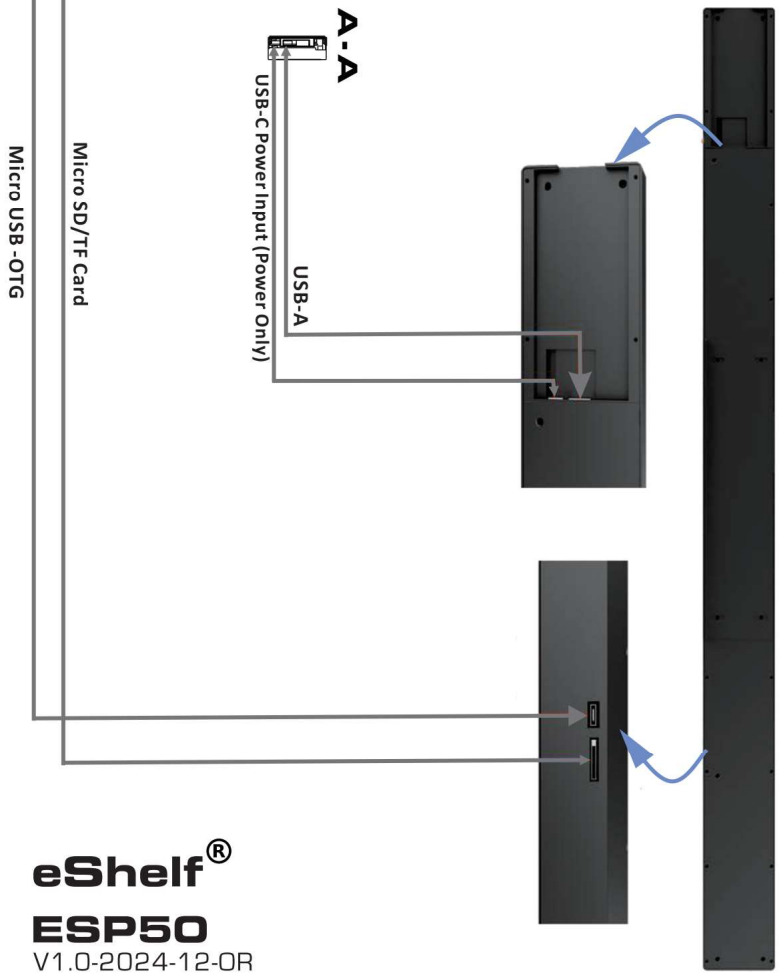
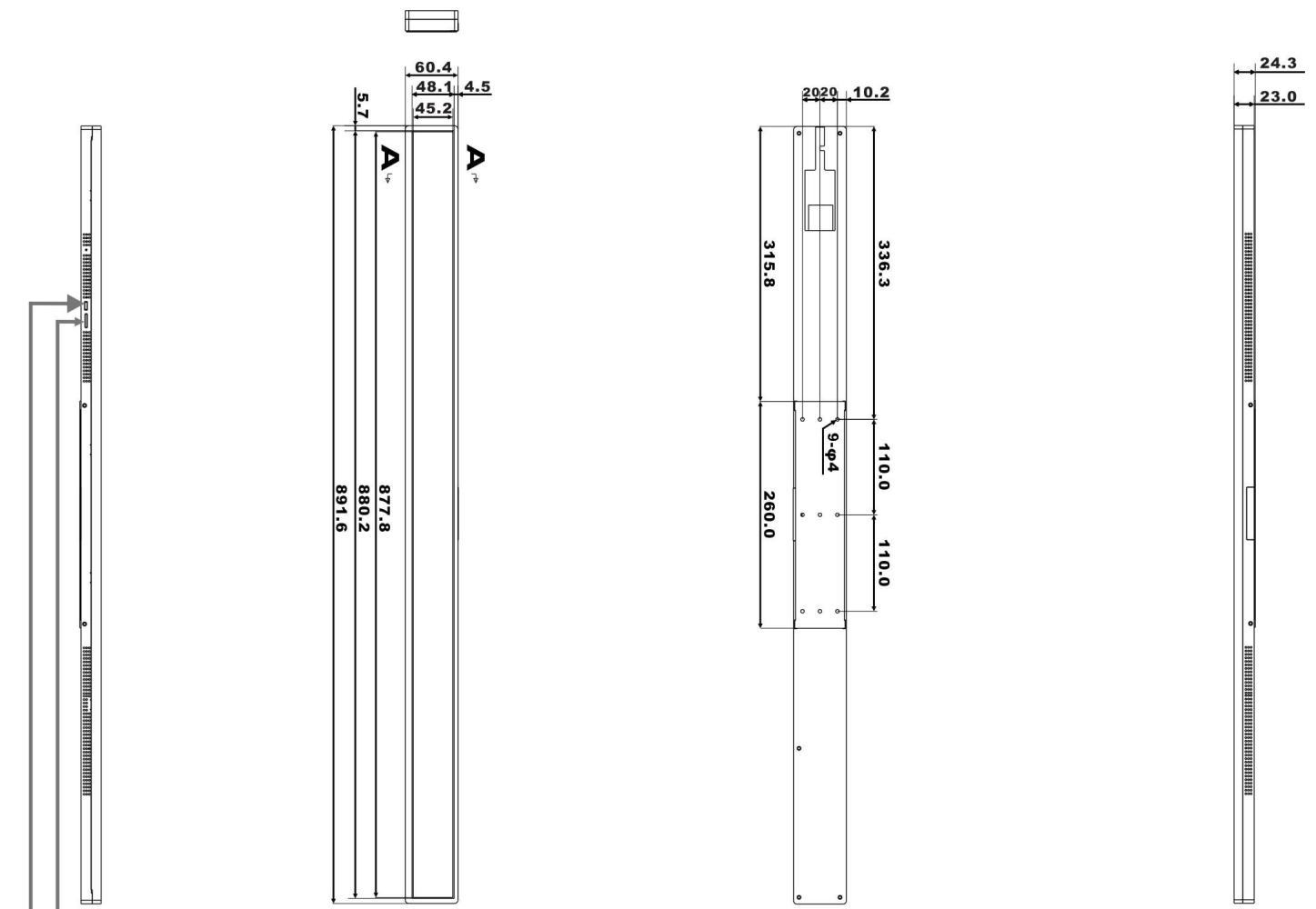

Avoiding Burn-In

To prevent eShelf burn-in,

- **AVOID** displaying static images or videos that have a static logo on eShelf
- **ALWAYS** incorporate dynamic content to maintain eShelf's quality over time.



eShelf[®]
ESP50
 V1.0-2024-12-OR

eShelf[®]		LUXX	
Item No.:	LUXX-ESP50-400	 	
Input Voltage:	12V DC		
Power:	Max.18W	 	
Screen Size:	35 inch		
Active Area:	878.4 x 48.19mm		
Resolution:	2880 x 158px		
System:	Andriod 9.0		
Radio:	2.4GHz 17.72dBm Max.		
		LUXX Light Technology (HK) Ltd. www.luxx.com	