

eShelf[®] ESP45-W 29" Digital Stretch Screen



Engaging shelf signage.



The 29" Digital Stretch Screen is a sleek, high-definition display designed for 24/7 operation, making it perfect for continuous use in retail, hospitality, and other commercial settings. This stand-alone unit supports independent playback, allowing you to effortlessly display content without needing a network connection. Ideal for digital signage applications that require clear, eye-catching visuals in compact spaces.

Whether you're showcasing promotions, menus, or product information, this durable and energy-efficient display delivers sharp, vibrant content around the clock.

Compatible

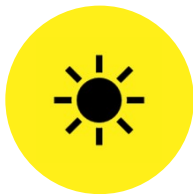

Compatible with a broad range of input voltages (15-36V DC), offering businesses flexibility in installation across different regions.

Convenient



This stand-alone unit offers hassle-free operation, allowing you to play content directly without the need for a network or external connections.

Reliable



Supports 24/7 continuous operation, ensuring your content stays visible and engaging around the clock.

Let your message stand out

With a vibrant digital display.

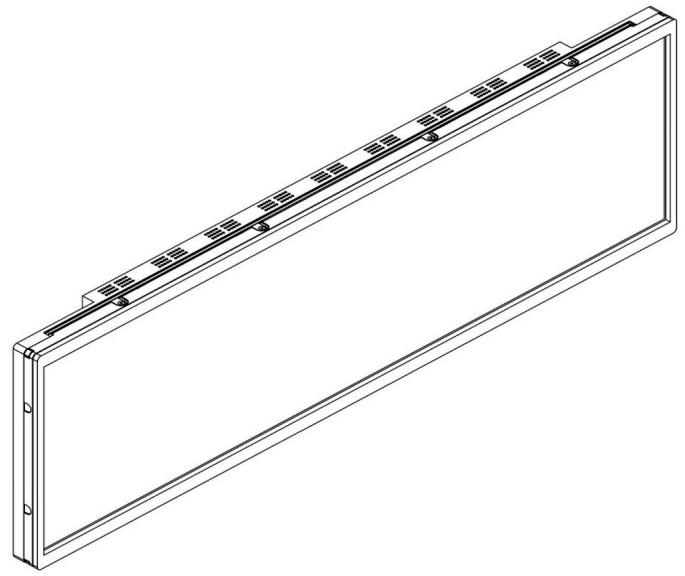

Panel

Size	29"
Active area	705.6(H) x 198.45(V) mm
Resolution	1920(V) x 540(H)
Backlight	LED
Lifespan	50000 hours
Viewing angle	178°(V) x 178° (H)
Contrast	1200: 1
Frequency	60 Hz
Display color	16.7M, 72% NTSC
Response time	8 ms

Systems

CPU	RKPX30 Quad core ARM Cortex-A35
RAM	1G DDR3 – 512MB*2 (1G/2G/4G/8G optional)
ROM	8G EMMC (8G/16G/32G/64G EMMC optional)
Memory extension	64G TF, TF Card extension with the highest support for 64GB
Networks	2.4G WIFI, support 2.4G WIFI connection
Bluetooth	Bluetooth V4.0
Interface	1*DC 5.5 Port Power Input, 1*USB-A (OTG), 1*USB-A, 1*TF card, 1*100M Broadband RJ 45 Network Port, 1*Earphone, 1*Reset Button, 1*IR Remote (Reserved Position). Must match with our special adapter for power supply
OS	Android 8.1

Mechanical Packaging

Dimension	720.8 x 226.5 x 40.2mm
N.W	≤ 4.4KG
Packing Dimension (2 Pcs/CTN)	830 x 210 x 300mm
G.W. (2 Pcs/CTN)	9.35KG

Accessories

Optional	Power adapter, Mounting bracket, OTC cable
----------	--

Power

Power consumption	≤ 30W
Voltage	DC 15-36V

Environment

Working environment	Temperature: 0°C ~ 50°C Humidity: 10% ~ 85% Atmospheric Pressure: 86kPa ~ 104kPa
Storage environment	Temperature: -20°C ~ 60°C Humidity: 5% ~ 95% Atmospheric Pressure: 86kPa ~ 104kPa

Warranty

Year	2Y
------	----

Supported Media Formats

- Audio - MP3, WMA, WAV, APE, FLAC, AAC, OGG, M4A, 3GPP formats
- Video - Multi-format 1080P 60fps video decoding (H.265, H.264, VC-1, MPEG-1/2/4, VP8), 1080P video encoding, supports H.264, VP8
- Picture - Supports browsing of various image formats such as JPG, BMP, PNG and supports rotation/slideshow/image enlargement functions

Note: LCD screens, including eShelf, may experience image retention or burn-in without effective content management.

What is Image Retention?

Image retention refers to any image that "sticks" on a screen, even when the content changes. It usually appears as a faint ghost that fades after a moment.

What is Image Burn-In?

Burn-in is a form of image retention that lasts much longer. It is a visible mark that remains, no matter what you are watching or doing.

Causes of Burn-In

- Videos that have a static logo, such as product logos, can leave a burn-in if displayed for a prolonged period
- Pausing a video and leaving the eShelf on for prolonged periods

Avoiding Burn-In

To prevent eShelf burn-in,

- **AVOID** displaying static images or videos that have a static logo on eShelf
- **ALWAYS** incorporate dynamic content to maintain eShelf's quality over time.

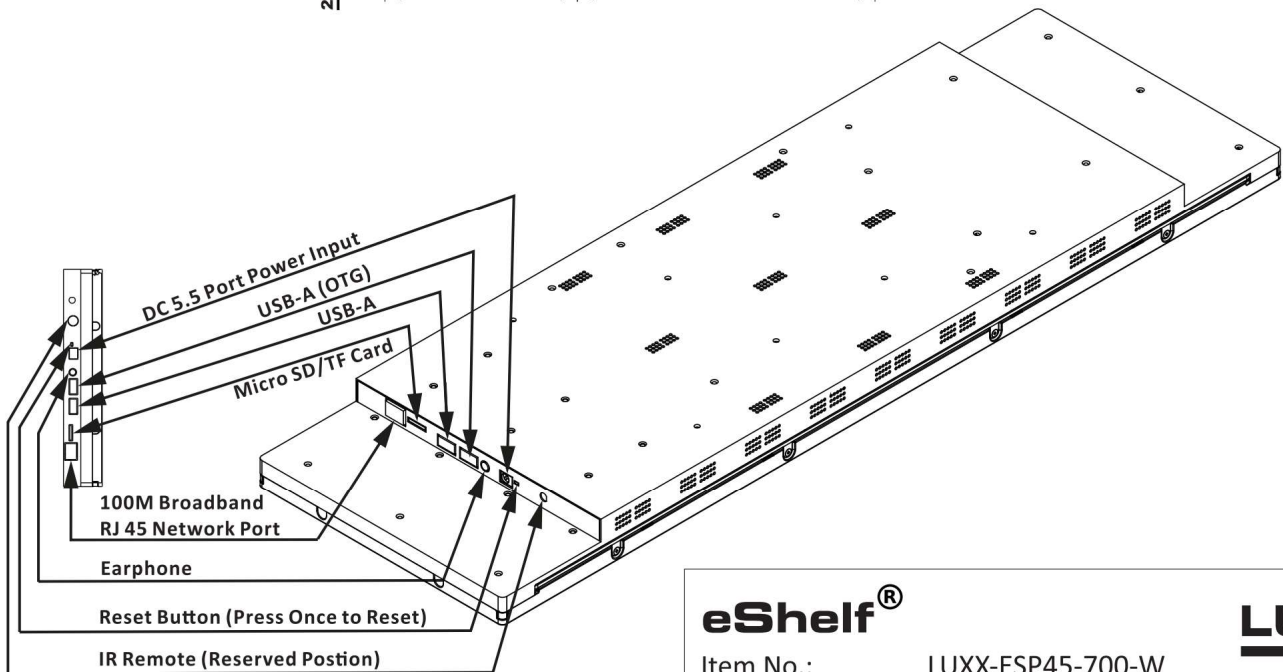
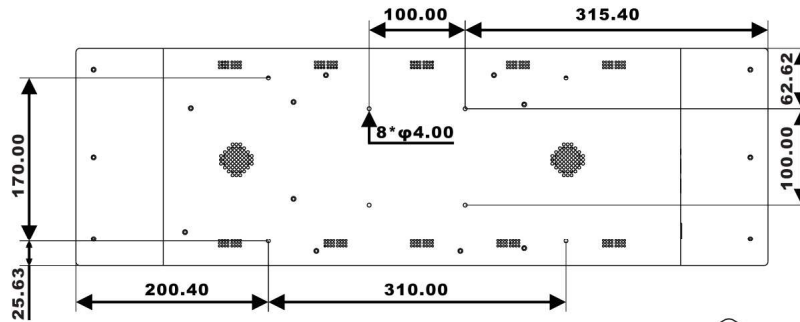
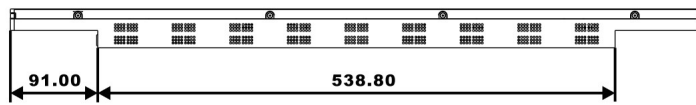
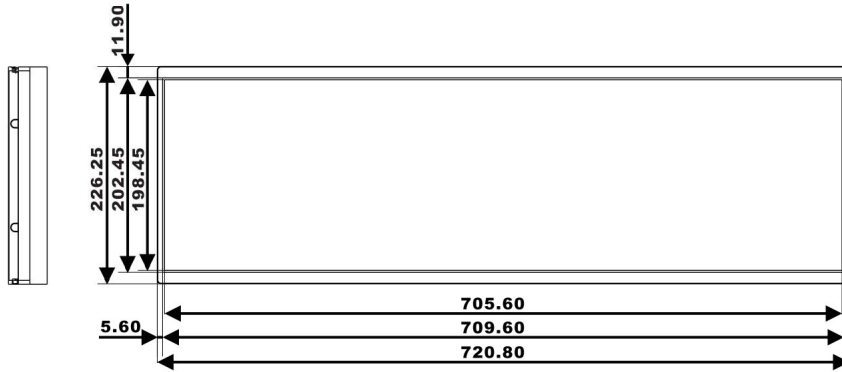
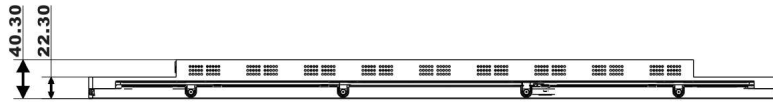

eShelf[®]
ESP45-W
 V1.0-2024-12-0R

eShelf[®]

Item No.: LUXX-ESP45-700-W
 Input Voltage: 15-36V DC
 Power: Max.30W
 Screen Size: 29 Inch
 Active Area: 705.6 x 198.45mm
 Resolution: 1920 × 540px
 System: Andriod 8.1
 Radio: 2.4GHz 17.72dBm Max.

LUXX



LUXX Light Technology (HK) Ltd.
 www.luxx.com